

Installing Instructions

INTERNATIONAL® CUB CADET HYDROSTATIC LINKAGE

FIELD CHANGE PACKAGE

8 007 448 R91

INTERNATIONAL® CUB CADET 109, 129, and 149 TRACTORS

INTERNATIONAL HARVESTER COMPANY

401 NORTH MICHIGAN AVE.

CHICAGO, ILLINOIS 60611, U.S.A.

Installation Procedure for Tractors with Top Snap Ring Serial No. 426 000 and below:

1. Remove the four bolts securing the transmission cover and remove the cover.

2. Remove the friction adjusting bolt.

3. Slide the speed control shaft up until snap ring is seated against instrument panel bushing. Measure gap between control rod arm and friction bushing flange. Determine how many spacers and washers must be added in this area to reduce the gap to a maximum of .064 inch.

4. Remove the 2 bolts securing the bushing support and remove the bushing support.

5. **IMPORTANT:** Clean lower end of shaft and apply a light coat of grease to the lower end of the shaft to insure that the bushing will not turn with the shaft. Grease must not be applied to the bushing support casting.

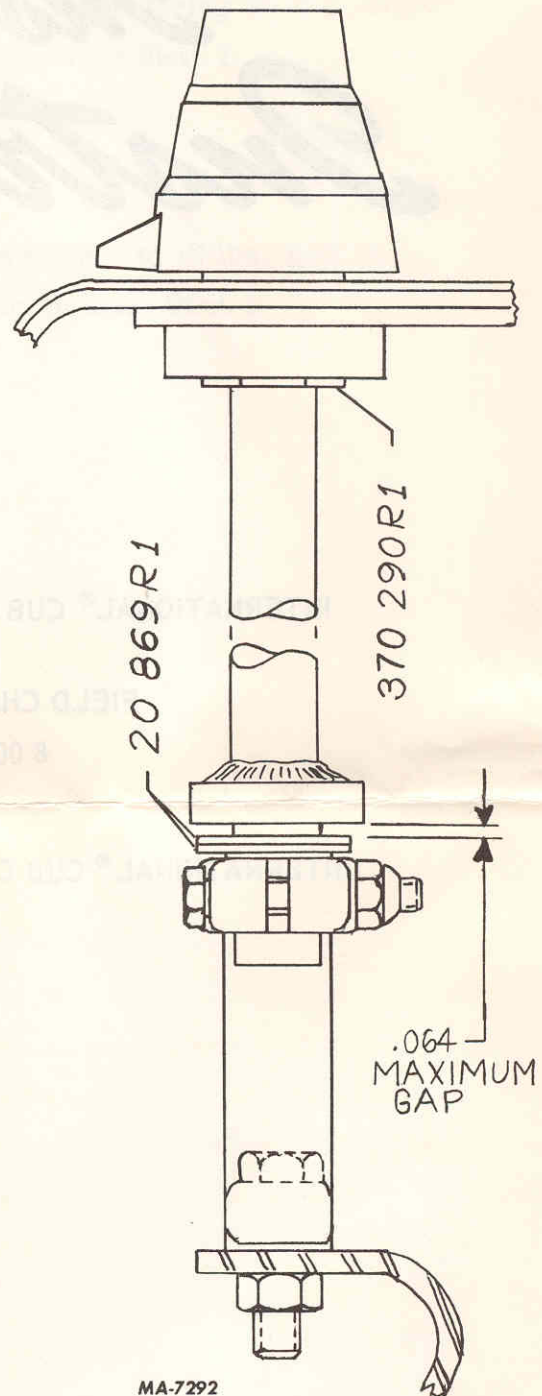

Illust. 1

6. Place the necessary number of spacers or washers on the shaft as determined in Step 4.

7. Install the new friction bushing in the support, and then slide the support up onto the shaft.

8. Install the 2 bolts securing the bushing support.

9. Recheck clearance between speed control arm and friction bushing flange to see that it has been reduced to .064 or less. If not, another washer must be added.

10. Install new adjusting screw, placing one safety spring washer under the head of the bolt and one under the nut as shown in Illust. 2.

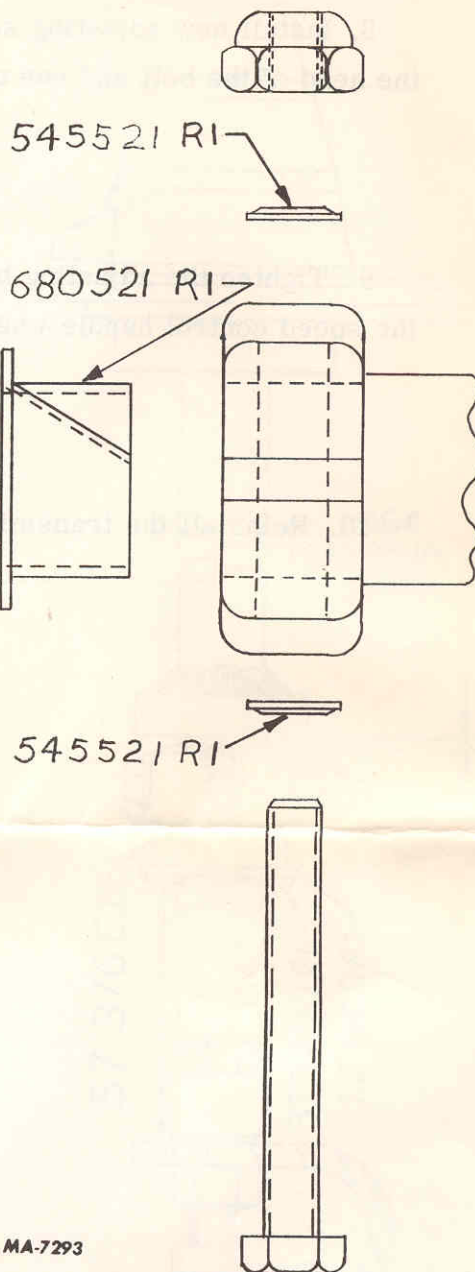

Illust. 2

11. Tighten the adjusting bolt until there is from 7 to 12 lbs. pull on the speed control handle when the handle is in motion. Illust. 3.

12. Reinstall the transmission cover.

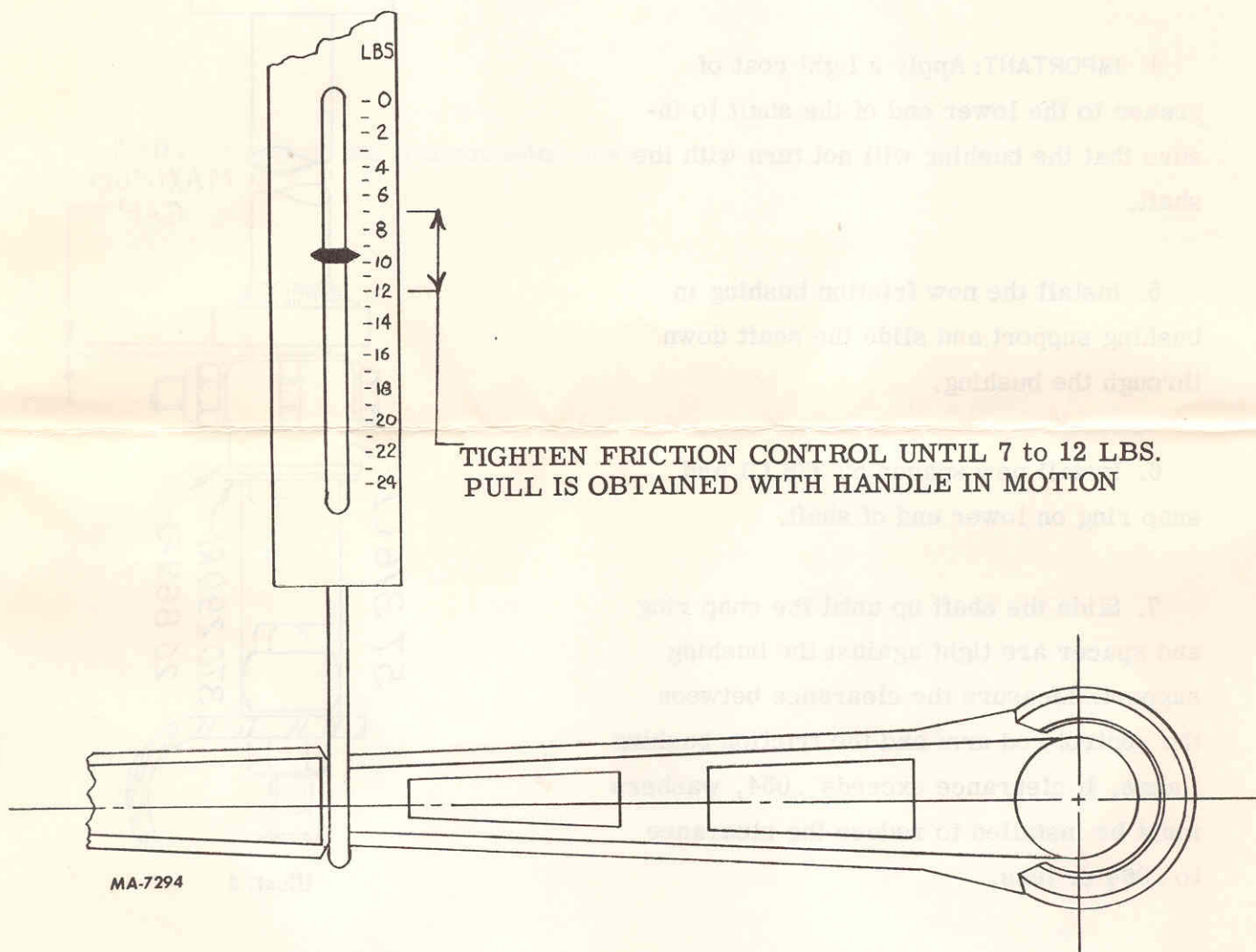

Illust. 3

1. Remove transmission cover.
2. Remove friction adjusting screw.
3. Remove snap ring on lower end of speed control shaft and slide shaft up. Clean the end of the shaft.
4. **IMPORTANT:** Apply a light coat of grease to the lower end of the shaft to insure that the bushing will not turn with the shaft.
5. Install the new friction bushing in bushing support and slide the shaft down through the bushing.
6. Install new spacer 57 376 C1 and snap ring on lower end of shaft.
7. Slide the shaft up until the snap ring and spacer are tight against the bushing support. Measure the clearance between the control rod arm and the friction bushing flange. If clearance exceeds .064, washers must be installed to reduce the clearance to .064 or less.

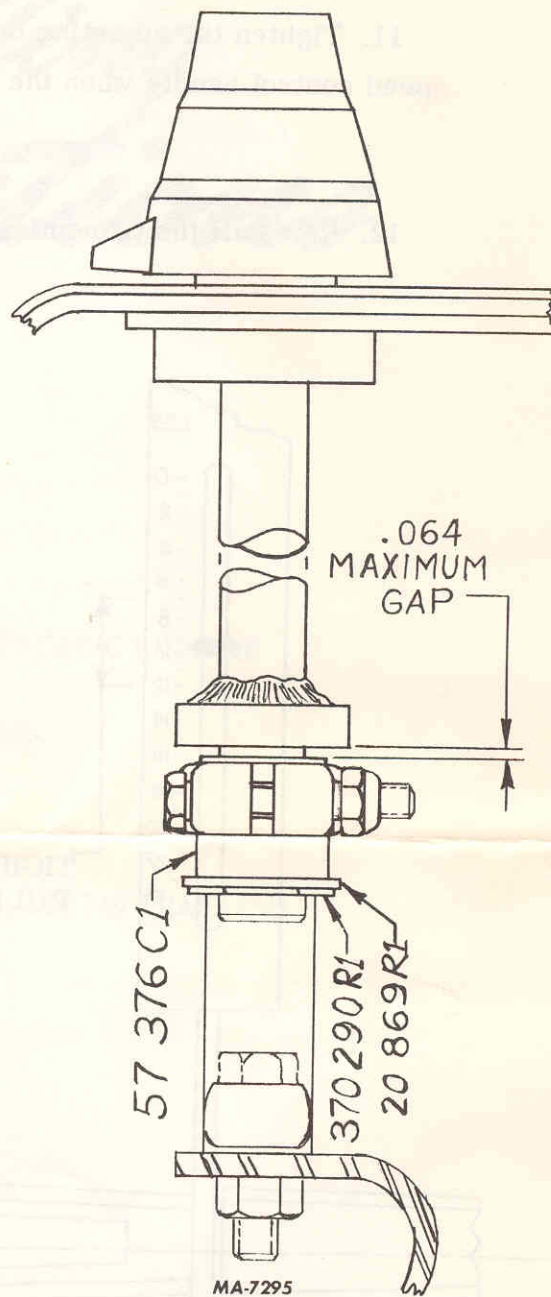

Illust. 4

8. Install new adjusting screw, placing one safety spring washer under the head of the bolt and one under the nut as shown in Illust. 2.

9. Tighten the adjusting bolt until there is from 7 to 12 lbs. pull on the speed control handle when the handle is in motion. Illust. 3.

10. Reinstall the transmission cover.